

Kenrahn LEVEL REGULATORS can be supported on their own double insulated PVC cable and easily adjusted to the switching level by raising or lowering the cable.
To prevent tangling, a brass weight is provided to submerge the float chamber when the level rises.
The switch action takes place as the float chamber passes the horizontal plane.

They can be used to automatically fill a tank or empty a pit, and are ideally suited for use in storm water, sewage or sump dewatering applications as well as fresh water conditions.

Description

The float chamber should be approximately 60 mm from the weight.
The distance is not critical, as the switching action takes place on the horizontal.
Please note that this style of level regulator is suitable for fine control of levels and will switch "ON" and "OFF" at approximately the same point.
For manual control only one level regulator is required, where as two or more are required for fully automatic systems.

Complete pumping systems with starters and level regulators to suit many applications are available from KENRAHN. There are standard twin pump panels to suit automatic control of sewage and storm water systems with audible or visual alarms.

Cross Section-Type CR

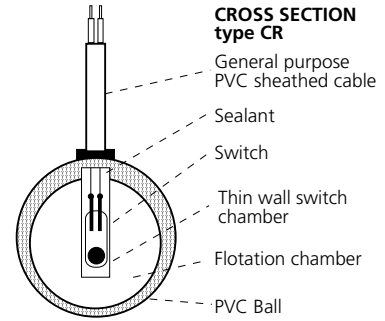

Typical connection diagram for three phase pump

EMPTYING or LOW LEVEL PROTECTION

MODEL
CR5 CR10 CR15 CR20

Used for emptying or high level alarm.

N/O Close on level rise.
Open on level fall.

Max. 150VA @ 240 Volt

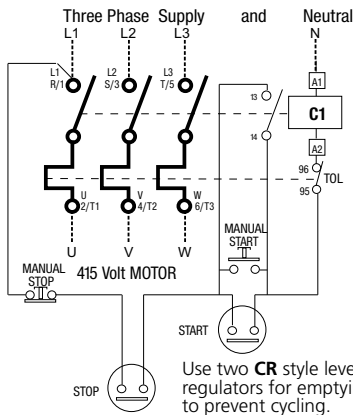

Use two CR style level regulators for emptying to prevent cycling.

KENRAHN Level Regulators "CR & CF" are made in Australia to suit local conditions and have provided trouble free pumping control since 1969.

Typical connection diagram for single phase pump

FILLING or HIGH LEVEL PROTECTION

MODEL
CF5 CF10 CF15 CF20

Used for filling or low level alarm.

N/C Open on level rise.
Close on level fall.

Max. 150VA @ 240 Volt

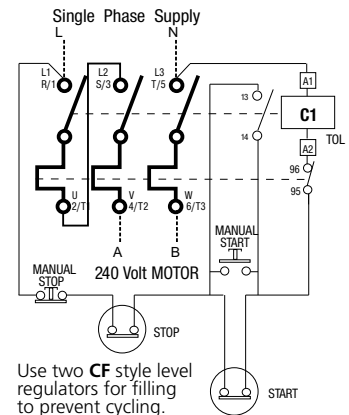

Use two CF style level regulators for filling to prevent cycling.

Typical installation with weights

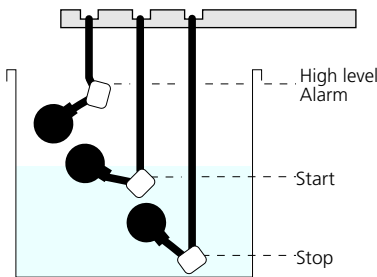

Typical installation without weights

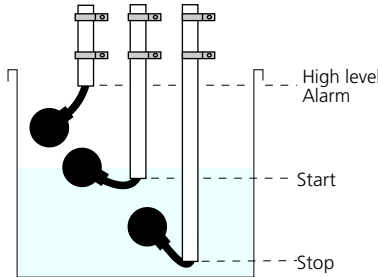

Technical details

Approval Number	CS4741N
Maximum operating current	2 Amp
Maximum switching VA	150 VA
Float chamber diameter	67 mm
Maximum working voltage	240 V ac
Minimum working voltage	6 V dc
Maximum working temperature	65 °C
Minimum working temperature	5 °C
Minimum switching depth	100 mm
Maximum submerged depth	20 mtr



CR-5

Selection and ordering data

MODEL	W	Amps	PRICE	Cable Length	Max. Volts	REMARKS
CR-5	150	2	59.00	5 metre	240	CR style = Close on level Rise = Open on level fall = N/O Normally open = PVC up to 65 °C = Emptying
CR-10	150	2	66.00	10 metre	240	
CR-15	150	2	73.00	15 metre	240	
CR-20	150	2	81.00	20 metre	240	
CF-5	150	2	59.00	5 metre	240	CF style = Close on level Fall = Open on level rise = N/C Normally closed = PVC up to 65 °C = Filling
CF-10	150	2	66.00	10 metre	240	
CF-15	150	2	73.00	15 metre	240	
CF-20	150	2	81.00	20 metre	240	
CR-OR-5	150	2	74.00	5 metre	240	xx-OR-xx style = Oil Resistant fitted with oil resistant cable for use with soaps, detergents and greases etc.
CR-OR-10	150	2	89.00	10 metre	240	
CF-OR-5	150	2	74.00	5 metre	240	